

**Aviation Fabricators Inc.  
805 North Fourth Street  
Clinton, MO. 64735**

## **INSTRUCTIONS FOR CONTINUED AIRWORTHINESS**

For  
Stretchers

**Document No.: AF-609**

**Revision "IR"**

**Revision Date: 10/06/14**

**Applicable to:**

**Beechcraft models: 36, A36, A36TC,  
B36TC, 58, 58TC, 58A, 58TCA**

**Modified by FAA STC:**

**SA00068WI**

The information in the Instruction for Continued Airworthiness is FAA accepted material and complies with 14 CFR 23.1529, Instructions for Continued Airworthiness. It supersedes or adds to that provided in the Maintenance Manual for the Beechcraft 36 & 58 Series Aircraft, only where covered in the items contained herein. For limitations and procedures not contained in the Supplement, consult the Component Maintenance Manual, or other approved airplane data.

## REVISION PAGE

Document Title: Instructions for Continued Airworthiness

Prepared By: Todd Pogue

Updates to the ICA will be made by Aviation Fabricators Inc. Updates will be listed in the log of revisions and the effective pages will be listed below.

<b>Log of Revisions</b>				
<b>REV. NO.</b>	<b>EFFECTED PAGE(S)</b>	<b>DESCRIPTION</b>	<b>DATE</b>	<b>APPROVED BY</b>
Orig. Issue	All	Initial Release	10/06/14	G.R. Lowe III

Per the requirement of Appendix G of 14 CFR Part 23 paragraph G23.1 (c), the changes made to the ICA by the applicant will be distributed via mail by means of paper copy.

## TABLE OF CONTENTS

DESCRIPTION	PAGE
INSTRUCTIONS FOR CONTINUED AIRWORTHINESS .....	1
REVISION PAGE .....	2
TABLE OF CONTENTS .....	3
1.0 INTRODUCTION.....	5
2.0 INSPECTION REQUIREMENTS AND OVERHAUL SCHEDULE.....	7
3.0 DIMENSION AND ACCESS: .....	10
4.0 LIFTING AND SHORING .....	10
5.0 LEVELING AND WEIGHING .....	10
6.0 TOWING AND TAXIING .....	10
7.0 PARKING AND MOORING.....	10
8.0 PLACARDS AND MARKINGS.....	11
9.0 SERVICE INFORMATION .....	11
10.0 AIRWORTHINESS LIMITATIONS .....	12
11.0 TROUBLESHOOTING.....	12

## ABBREVIATIONS AND DEFINITIONS

<b>Abbreviations</b>	<b>Definitions</b>
AML	FAA Approved Model List (AML)
Detailed Inspection (DET)	An intensive examination of a specific item, installation or assembly to detect damage, failure or irregularity. Available lighting is normally supplemented with a direct source of good lighting at an intensity deemed appropriate. Inspection aids such as mirrors, magnifying lenses, etc. may be necessary. Surface cleaning and elaborate access procedures may be required.
FAA	Federal Aviation Administration
FAA MIDO	FAA Manufacturing Inspection District Office
General Visual Inspection (GVI)	A visual examination of an interior or exterior area, installation or assembly to detect obvious damage, failure or irregularity. This level of inspection is made from within touching distance unless otherwise specified. A mirror may be necessary to enhance visual access to all exposed surfaces in the inspection area. This level of inspection is made under normally available lighting conditions such as daylight, hangar lighting, flashlight or droplight and may require removal or opening of access panels or doors. Stands, ladders or platforms may be required to gain proximity to the area being checked.
ICA	Instructions for Continued Airworthiness
Special Detailed Inspection (SDI)	An intensive examination of a specific item, installation , or assembly to detect damage, failure or irregularity. The examination is likely to make extensive use of specialized Inspection Techniques and/or equipment. Intricate cleaning and substantial access or disassembly procedure may be required.
STC	Supplemental Type Certificate

## 1.0 INTRODUCTION

The purpose of this Maintenance Manual Supplement and Instructions for Continued Airworthiness (ICA) is to provide the maintenance technician with the information necessary to ensure the continued airworthiness of the Aviation Fabricators stretcher installation, per installation numbers 32-0114K, 32-0114K-X when installed in accordance with Aviation Fabricators design data included on STC Drawing List AF-162 per Supplement Type Certificates (STC) SA00068WI.

Modifications to an aircraft obligates the operator to include the maintenance information provided by this document into the operators aircraft Maintenance Manual and operator's aircraft scheduled maintenance program. This document defines supplementary maintenance operations and frequencies recommended by Aviation Fabricators Inc., to ensure the aircraft's airworthiness.

The information contained herein addresses the requirements specified in 14 CFR 23.1529, Instructions for Continued Airworthiness and supplements the basic Airplane Maintenance Manual only in those areas listed as pertains to the installation of the stretchers, as installed per the Aviation Fabricators STC Drawing List AF-162. For limitations and procedures not contained in this supplement, consult the Airplane Maintenance Manual.

### DATA

All information to support the continued airworthiness of this modification is contained in:

STC SA00068WI  
STC Drawing List: AF-162

Installation: STC Drawing Lists: AF-162:  
Drawing AF-115 for p/n's 32-0114K and 32-0114K-X

Parts: Refer to p/n's 32-0114 on respective drawings as listed on STC Drawing Lists AF-162.

The stretcher is a self contained complete assembly that mounts to the existing seat track and foot fittings, using standard fittings and hardware.

### Design Change Control

All data and changes to the parts and assemblies will be tracked per STC Drawing List AF-162 latest approved revisions.

### Applicable Aircraft

Beechcraft models: 36, A36, A36TC, B36TC, 58, 58TC, 58A, 58TCA aircraft.

**Stretcher Assemblies**

P/N's 32-0114K, 32-0114K-1 (shown) , 32-0114K-2

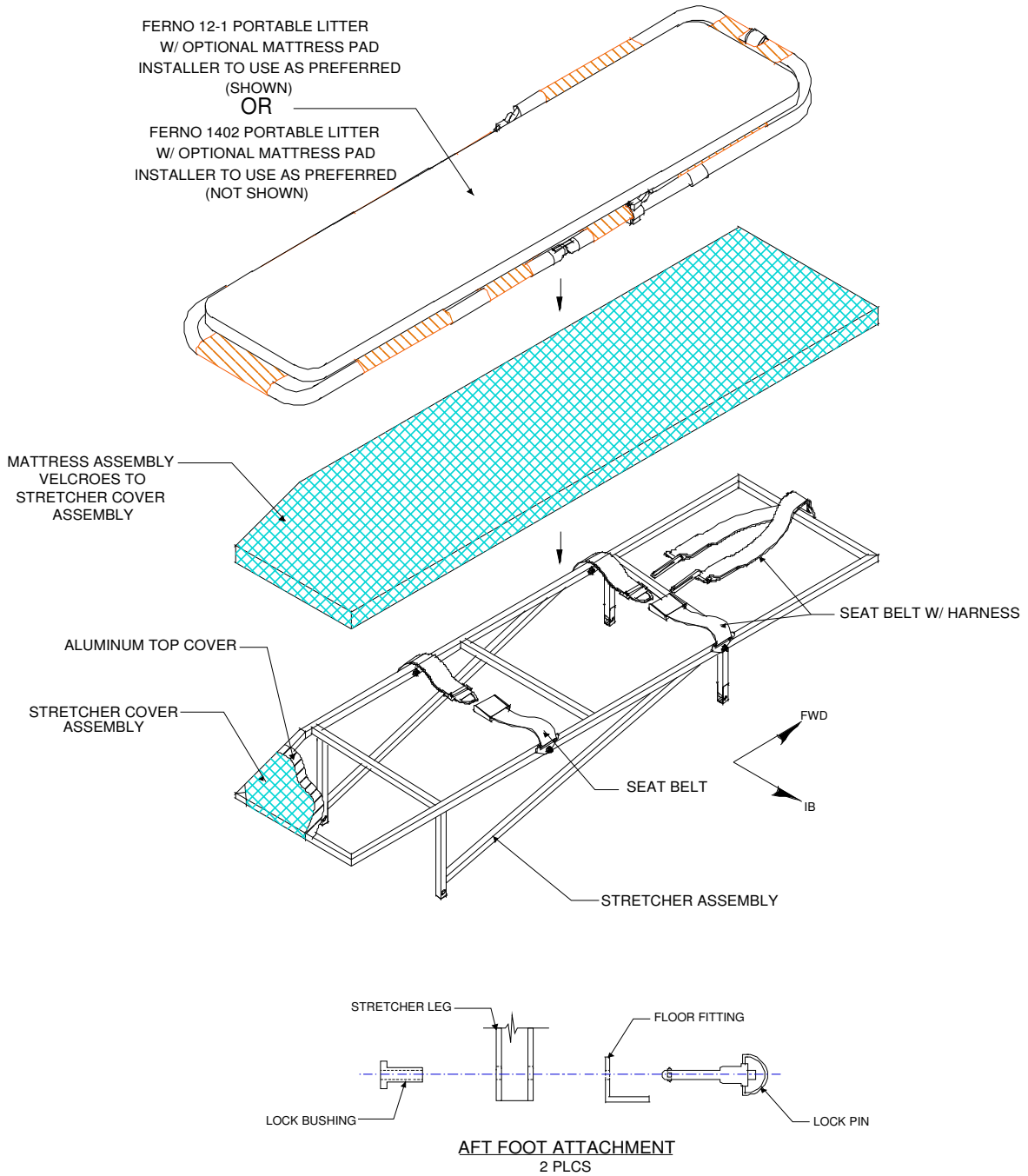

**Figure 1.0A**

### Seat Belt & Shoulder Harness Attachment

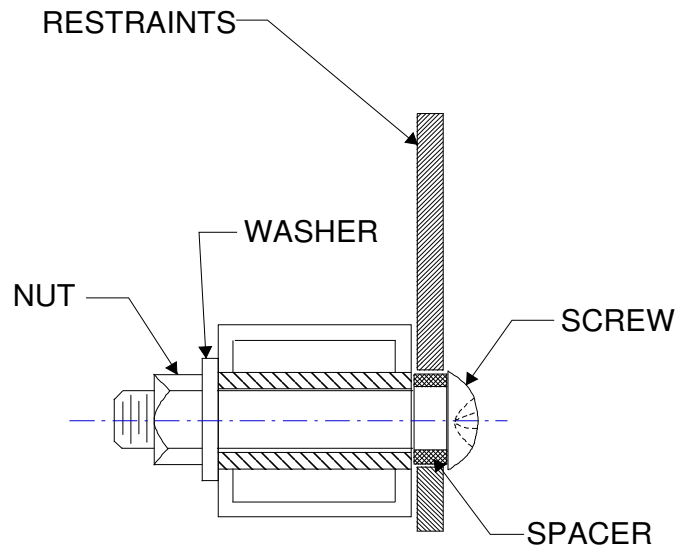

**Figure 1.0B**

## **2.0 INSPECTION REQUIREMENTS AND OVERHAUL SCHEDULE**

1. To comply with 14 CFR 23.1529, continue the new stretcher and restraint system on the same inspection and maintenance schedule used per the applicable Beechcraft Maintenance Manual for seats.
  - a. The new stretcher and restraint systems require no service other than inspection at normal inspection interval of 100 hours or annually.
  - b. Perform a detailed visual inspection of the stretcher mattress bottom and top covering to detect apparent or obvious defects or irregularities.

On the mattress assembly, check for cracks and punctures within a 4" diameter circle. The mattress assembly can have no more than three defects found within the 4" diameter circle. If it develops a "lump", check to see if there are no more than two lumps within a 4" diameter circle. Any damage to the mattress assembly outside of the described limits will require it to be replaced.

Visually inspect the covering assembly for holes, punctures, and tears. If the damage to the covering is holes smaller than 1/2" in diameter or a cut at a maximum of 2" in length then the covering is satisfactory. The sewing of the cover assembly cannot have a tear or cut exceeding 1" in length. Any damage to the covering assembly outside of the described limits will require it to be replaced.

- c. Visually inspect the stretcher assembly tubing and diaphragm for cracks and deformation. Damaged conditions can be detected as a crack at the edge of the tube or along the length of the tubes or as a crack, tear or cut found on the seat bottom diaphragm. Visually inspect all hardware for excessive wear before and after installation.

Replace the stretcher top diaphragm if two cracks or deformations are found within a 4" diameter circle. If a tear or cut is found with a maximum 6" length, replace the diaphragm.

There shall be no broken tubes. There shall be no sharp corners, edges, or protrusions that may injure passengers. Replace the tubes if they are bent in such a way that they are more than 2" off center. Replace the stretcher tubes if crack length is found to be .125" or greater. Replace the tube if a dent is found running longer than 3". Replace the stretcher tubes if deformation is greater than .25" the overall thickness of the tube diameter.

Cracked or broken fasteners or fittings are to be replaced with new immediately.

For repair or replacement of damaged or broken parts or assemblies contact Aviation Fabricators Inc.



2. Inspection Time Limit for Stretcher Assembly Installations:

100 hour or annual inspection for the stretcher and restraint systems

Task Code			Schedule	Date	Mech	Insp
AFI-100	a.	Inspect for damage to upholstery.				
AFI-101	b.	Inspect safety belts for wear, cuts, fraying, damage, and deterioration.				
AFI-102	c.	Inspect safety belt attachment fittings for wear and damage				
AFI-103	d.	Inspect foot fittings for damage, security, and function.				
AFI-104	e.	Inspect stretcher frame for damage, and corrosion.				
AFI-105	f.	Inspect overall stretcher assembly for fit and function.				

A. The new stretcher and restraint system are on the same inspection and maintenance schedule used per the applicable Beechcraft Maintenance Manual for passenger seats.

### 3.0 DIMENSION AND ACCESS:

The installation of the stretcher assembly does not change the dimensions of the aircraft or alter the access to any existing aircraft system.

### 4.0 LIFTING AND SHORING

No change.

### 5.0 LEVELING AND WEIGHING

Stretcher w/ Seat Belts	=	21 lbs	
Optional Mattress	=	8.5 lbs	
Ferno 12-1 Portable Litter	=	15 lbs	
Ferno 1403 Portable Litter	=	<u>25 lbs</u>	
Total	=	44.5 lbs	54.5 lbs
Stretcher Length	=	72 inches	

### 6.0 TOWING AND TAXIING

No change.

### 7.0 PARKING AND MOORING

No change.

## 8.0 PLACARDS AND MARKINGS

No change.

## 9.0 SERVICE INFORMATION

### Typical Stretcher Service Instructions:

#### A. Upholstery Cleaning:

##### Stretcher Service Instructions

1. Remove the mattress and cover assemblies from the stretcher.
2. Clean covering with Armour All leather cleaner or equivalent.
3. Clean drawer finish using Armour All multi-purpose cleaner or equivalent.
4. Clean and inspect restraint system for damage or excessive wear.
5. Inspect all attachment fittings and replace if necessary.
6. Inspect overall stretcher for fit and function.

### Typical Stretcher Service Instructions:

#### Stretcher Assembly

The stretcher is a self contained complete assembly that mounts to the existing seat track and foot fittings, using standard fittings and hardware.

To remove the stretcher assembly from the aircraft removed lock pins and bushing from aft leg attaching points and slide stretcher off forward track.

To install the stretcher slide the forward feet on existing T track and then align the aft legs to the existing foot fittings. Secure into place using existing lock pins and bushings. Refer to Figure 1.0A.

#### Mattress and Seat Cover

The mattress assembly is removed by simply pulling it upward from the Velcro on the stretcher cover. The stretcher cover is removed by pulling it away from the Velcro on underside of the stretcher top frame.

#### Seat Belt and Shoulder Harness

Seat belt and Shoulder Harness removal is accomplished by loosening attaching hardware and removing from the stretcher frame assembly. Refer to Figure 1.0B.

## B. RECOMMENDED OVERHAUL PERIODS

No additional overhaul time limitations and requirements apply to the Aviation Fabricators Stretcher Assemblies.

## **10.0 AIRWORTHINESS LIMITATIONS**

The Airworthiness Limitations section is FAA approved and specifies maintenance required under Sec. 43.16 and 91.403 of the Federal Aviation Regulations unless an alternative program has been FAA approved.

There are no Airworthiness Limitations to the aircraft with the addition of the Stretcher Assembly installed by this STC.

## **11.0 TROUBLESHOOTING**

Refer to the existing Aircraft Maintenance Manual for troubleshooting the stretcher installation that is required beyond the information found on the installation drawing AF-115.

For replacement parts or repair of damage parts:

Contact Aviation Fabricators at (660) 885-8317.

Troubleshooting this installation should only be accomplished by FAA approved repair stations with the appropriate ratings or appropriately rated operator/individuals, with required test equipment and service data.